

Code: 15A03101

SS

B.Tech II Year II Semester (R15) Regular Examinations May/June 2017

**ENGINEERING DRAWING**  
(Electronics and Communication Engineering)

Time: 3 hours

Max. Marks: 70

(Answer all five units, 05 X 14 = 70 Marks)

\*\*\*\*\*

**UNIT – I**

1 A string of length 108 mm is wound round a pentagon of 20 mm side. Draw the path traced by the end of the string.

**OR**

2 Construct a rectangular hyperbola when a point P on it is at a distance of 15 mm and 20 mm respectively from the two asymptotes.

**UNIT – II**

3 Draw a vernier scale of R.F = 2:1 to show centimeters and millimeters and long enough to measure up to 7 cm. Measure a distance of 4.25 cm on the scale.

**OR**

4 A fan is hanging in the center of a room 4 m x 4.5 m x 4 m high. The center of the fan is 0.6 m below the ceiling. Determine graphically the shortest distance of the fan from one of the corners of the floor.

**UNIT – III**

5 A hexagonal lamina of 20 mm side rests on one of its corners on the HP. The diagonal passing through this corner is inclined at 45° to HP. The lamina is then rotated through 90° such that the top view of this diagonal is perpendicular to the VP and the surface is still inclined at 45° to the HP. Draw the projections of the lamina.

**OR**

6 A pentagonal prism side of base 25 mm and axis 50 mm long rests with one of its edges on HP such that the base containing that edge makes an angle of 30° to HP and its axis is parallel to VP. Draw its projections.

**UNIT – IV**

7 Draw the development of the lateral surfaces of square pyramid side of base 25 mm and height 50 mm, resting with its base on HP and an edge of the base parallel to VP.

**OR**

8 Draw the development of the lateral surfaces of a cone of base diameter 50 mm and altitude 80 mm.

Contd. in page 2

UNIT - V

9 Draw the isometric projection of a sphere of diameter 50 mm resting centrally on the top of a cube of side 60 mm.

OR

10 Draw the front view, top view and side view for the following isometric view.

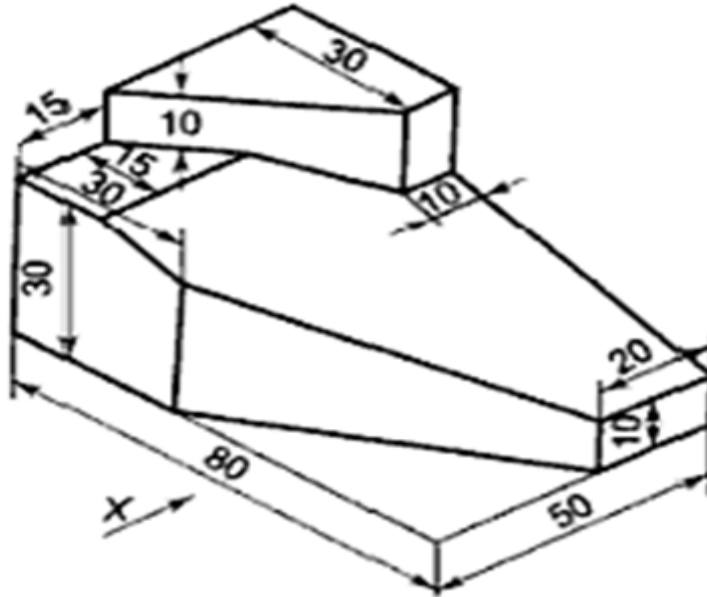

\*\*\*\*\*